

Introduction

The CO2/RH/T transmitter incorporates three sensors in one attractive wall mount enclosure for the most efficient environmental monitoring and control system. It uses Infrared Technology to monitor CO2 levels within a range of 0–2000 ppm or 20,000 ppm , a field-proven RH sensor to monitor relative humidity from 0-100 %RH and a curve-matched thermistor to measure temperature over common field-selectable ranges. All three measurements are continuously available on separate outputs as linear 4-20 mA or 0-5/0-10 Vdc signals. The device includes an LCD for configuration and operating parameters are programmed using a keypad for specific applications. Options include a control relay, override switch and slide pot setpoint control.

Before Installation

Read these instructions carefully before installing and commissioning the CO2/RH/T transmitter. Failure to follow these instructions may result in product damage. Do not use in an explosive or hazardous environment, with combustible or flammable gases, as a safety or emergency stop device or in any other application where failure of the product could result in personal injury. Take electrostatic discharge precautions during installation and do not exceed the device ratings.

Mounting

The room type sensor installs directly on a standard electrical box and should be mounted five feet from the floor of the area to be controlled. Do not mount the sensor near doors, opening windows, supply air diffusers or other known air disturbances. Avoid areas where the detector is exposed to vibrations or rapid temperature changes.

The cover is hooked to the base at the top edge and must be removed from the bottom edge first. Use a small screwdriver to carefully pry each bottom corner if necessary. If a security screw is installed on the bottom edge, then it may have to be loosened or removed also. Tip the cover away from the base and sit it aside.

The pcb must be removed from the base to access the mounting holes. Follow usual anti-static procedures when handling the pcb and be careful not to touch the sensors.

The pcb is removed by pressing the enclosure base to unsnap the latch near the bottom edge, then the pcb can be lifted out of the base. Sit the pcb aside until the base is mounted on the wall.

After the base is screwed to an electrical box or the wall using the appropriate holes, pull the wires through the wiring hole in the center of the pcb and then reinstall it in the enclosure base. Ensure the pcb is snapped into the base securely and correctly.

The mounting hole locations are shown in the following drawing.

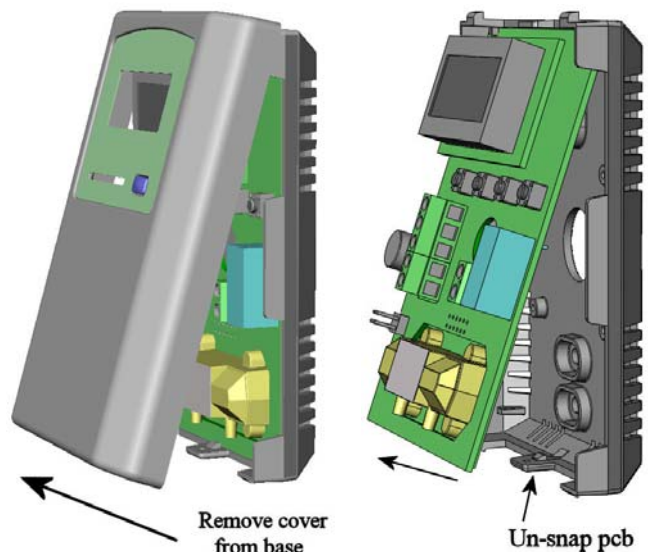
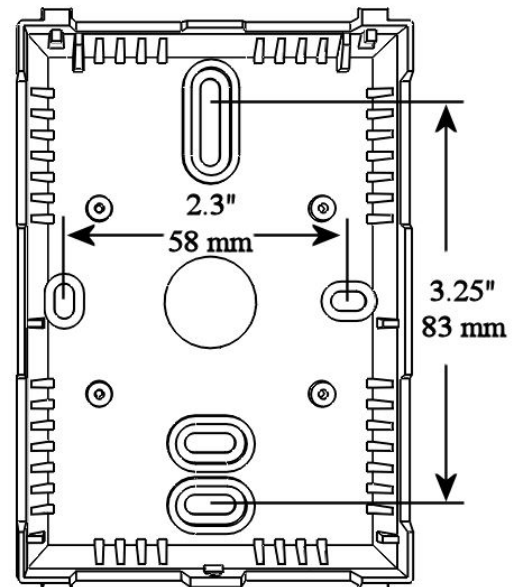

Wiring

Deactivate the 24 Vac/dc power supply until all connections are made to the device to prevent electrical shock or equipment damage. Follow proper electrostatic discharge (ESD) handling procedures when installing the device or equipment damage may occur. Use 22 AWG shielded wiring for all connections and do not locate the device wires in the same conduit with wiring used to supply inductive loads such as motors. Make all connections in accordance with national and local codes.

This is a 3-wire sourcing device. Connect the plus dc or the ac voltage hot side to the **PWR** terminal. The supply common is connected to the **COM** terminal. The device is reverse voltage protected and will not operate if connected backwards. It has a half-wave power supply so the supply common is the same as the signal common. Several devices may be connected to one power supply and the output signals all share the same common. Use caution when grounding the secondary of a transformer or when wiring multiple devices to ensure the ground point is the same on all devices and the controller.

The analog outputs are available on the **CO2**, **RH** and **TEMP** terminals. The signal type can be ordered as either voltage or 4-20 mA active outputs. The voltage model is selectable for either 0-5 or 0-10 Vdc via the menu (the factory default is 0-5 Vdc). The current output operates in the active mode and does not require a loop power supply. This means that the signal current is generated by the transmitter and must not be connected to a powered input or device damage will result. Check the controller Analog Input to determine the proper connection before applying power. Both current and voltage signals are referenced to the **COMMON** terminal. The analog output signals are typically connected directly to the Building Automation System (B.A.S.) and used as control parameters.

An optional signal is the relay output available on the **N.O. RELAY** terminals. The relay output is completely isolated and has a Normally Open (NO) signal. This signal can be used to directly control an alarm or ventilation fan.

If installed, the override switch output is a two-wire dry contact normally open switch contact. The slide pot output is a two-wire resistive signal that can vary from 0-10K ohms (for example) with left-to-right slide pot action. Other resistive values are available on request and the slide pot may be configured as normal or reverse acting.

The override switch and slide pot share a single common labelled **S. COM** and this is not connected to the power supply **COM**.

Typical 4-20 mA wiring with 24 Vdc

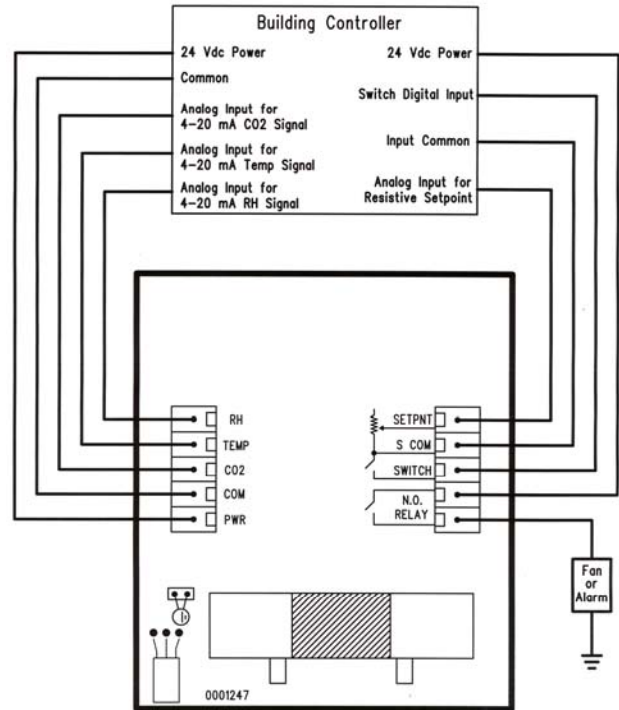

Typical 0-5 Vdc wiring with 24 Vac

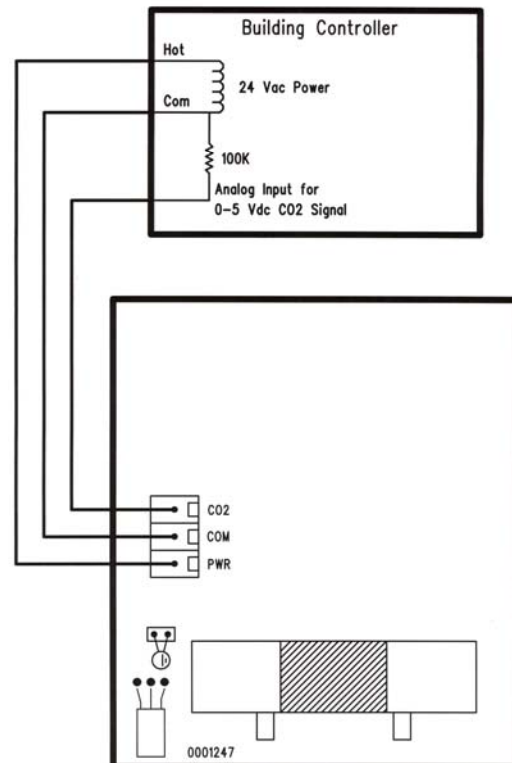

Start-up

Verify the transmitter is properly wired and connections are tight. Apply power and note that the CO2 sensor chamber light flashes on and off. The LCD will indicate the software version number, the relay setpoint (if installed), the CO2 measurement range, the temperature range and then the device will begin reading the sensor values and display them on the LCD. The sensor will update the output and display every 4 seconds.

Outputs

The CO2 output is scaled so that 4-20 mA (or 0-5/0-10 Vdc) equals 0 to Out_High as set in the Setup menu. Depending on the model ordered, the factory default is either 0-2000 ppm or 0-20,000 ppm. The Out_High can be changed in the Setup menu and the output signal is scaled accordingly.

The RH and temperature outputs operate similar to the CO2 output. RH is scaled 0-100 %RH and temperature defaults to 32-95 °F but can be changed to 0-35 °C, 0-50 °C or 32-122 °F using the Setup Menu.

For voltage output models, the factory default is 0-5 Vdc and can be changed to 0-10 Vdc in the Setup Menu.

Operation

The CO2, RH and Temperature signals are connected to the BAS analog inputs. The BAS reads the voltage or current signals and calculates actual values using correct scaling for the ranges and signal type. These values can be used to control ventilation devices or initiate alarms. All values are displayed locally on the LCD. The Setup Menu can be used to modify the displayed information.

The display is factory set to display all three measurement values. The CO2 level will be displayed as 0-2000 ppm or 0-20,000 ppm depending on the model, the %RH will be displayed as 0-99H and the temperature will be displayed as 32-95°F. The Setup menu can be used to modify the displayed information. The installer can select to only display CO2, or to display CO2 and RH, or alternately CO2 and temperature. The device supports four temperature ranges that may also be selected in the menu. The default is 32-95°F but this may be changed to 0-35°C and the output signal will stay the same. Also, the temperature range may be changed to 32-122°F or 0-50°C and the output scaling will change to match the display.

If the optional relay is installed it can directly control a small fan or alarm by setting the trip value and hysteresis to appropriate values. The relay status is not indicated on the device LCD.

The optional override switch provides a dry contact closure to a digital input of the B.A.S. The switch status is not indicated on the LCD.

The optional slide pot can be connected to an analog input of the B.A.S. and will provide a linear resistance signal such as 0-10 KΩ (for example) to be used as a setpoint control. The setpoint value is not shown on the LCD.

Calibration

The RH and temperature measurements typically do not need any calibration for the life of the product. Both values may have user offsets assigned in the Setup Menu.

CO2 calibration with gas requires a field calibration kit with pressure regulator, necessary tubing and appropriate bottles of CO2 gas. Note that the procedure depends on the device model. The standard model requires only a single point 1000 ppm calibration to meet specified accuracy due to the Automatic Calibration Mode and other technology incorporated into the CDD5A/B series.

The CDD5C/D dual-channel sensor with extended range requires a 3-point calibration with 0, 1000 and 20,000 ppm gas (in order).

0 PPM Calibration (For CDD5C/D models only)

Turn the regulator knob off and attach it to the Nitrogen gas bottle and hand tighten. Open the cover of the unit to be calibrated to expose the gas sensor chamber. The tubing from the gas bottle can be connected to either port on the chamber after the protective plastic cap is removed. Gently remove one cap and connect the tubing, note that strong shock or vibration can affect calibration.

Ensure the device has been operating normally for at least five minutes before applying gas. Turn the valve knob on the regulator to start the gas flow. The regulator will restrict the flow rate to the specified 100 ml/min. After a brief period the gas will flow into the chamber. Wait 1 to 2 minutes while the CO2 stabilizes.

Enter the Setup menu and use the <MENU> key to advance to **Calibrat 0 PPM**. Press and hold the <SAVE> key for 2 seconds and the display will change to **Waiting Calibrat** then to **Waiting 5 minute** to indicate that the process of setting the internal calibration is taking place.

This takes about 5 minutes while the LCD counts down. Do not disturb the unit or the gas flow. When complete the unit will display **Calibrat Done**. Press the <SAVE> key to return to normal operation and shut the gas off.

1000 PPM Calibration (For all CDD models)

Connect the 1000 ppm CO2 gas bottle and apply the gas as described above. The CO2 reading on the LCD will

begin to approach 1000 ppm. Wait 1 to 2 minutes while the CO2 reading stabilizes.

Enter the Setup menu and use the <MENU> key to advance to **Calibrat 1000 PPM**. Press and hold the <SAVE> key for 2 seconds and the display will change to **Waiting Calibrat** then to **Waiting 5 minute** to indicate that the device is calibrating. Again, this process takes about 5 minutes. When calibration is complete the unit will display **Calibrat Done**. Press the <SAVE> key to return to normal operation and shut the gas off.

20,000 PPM Calibration (For CDD5C/D models only)

Connect the 20,000 ppm CO2 and apply the gas as before. The LCD will begin to approach 20,000 ppm. Wait 1 to 2 minutes while the CO2 reading stabilizes.

Enter the Setup menu and use the <MENU> key to advance to **Calibrat 20,000 PPM**. Press and hold the <SAVE> key for 2 seconds and the display will change to **Waiting Calibrat** then to **Waiting 5 minute**.

Again, wait 5 minute and when calibration is complete the unit will display **Calibrat Done**. Press the <SAVE> key to return to normal operation and shut the gas off. Disconnect the tubing and replace the cap on the sensor chamber as calibration is complete.

Setup Menu

The menu has several items shown below. Some items change depending on the hardware configuration and the CO2 sensor. To enter the menu, press and release the <MENU> key while in normal operation. This enters the SETUP menu step 1, pressing the <MENU> key again advances to step 2. Each press of <MENU> advances the menu item. No values are saved or changed by using <MENU>. The <ROLL> key is used to make changes to program variables by scrolling through the available options. When a value is changed, use the <SAVE> key to save it to memory and advance to the next menu item.

<MENU> Press and release the <MENU> key to enter the SETUP menu

If the 2000 ppm CO2 sensor is installed (CDD5A/B models)

1. Out High 2000 ppm The default CO2 range is 0-2000 ppm. The span can be changed from 1000 to 7500 ppm in increments of 500. Use the <ROLL> key to change the value and <SAVE> to save. The factory default is 2000 ppm.

If the 20,000 ppm CO2 sensor is installed (CDD5C/D models)

1. Out High 20000 ppm The default CO2 range is 0-20,000 ppm. The span can be changed from 2000 to 20,000 ppm in increments of 500. Use the <ROLL> key to change the value and <SAVE> to save. The factory default is 20,000 ppm.

<MENU>

2. Altitude 0 Ft The default is 0 feet. Change by using the <ROLL> key from 0 to 5000 feet in 500 ft increments. Change for CO2 local altitude correction and press <SAVE> to save a change.

<MENU>

This item is omitted if the 20,000 ppm dual-channel sensor is installed

3. Auto Cal ON Automatic Cal Mode default is ON to correct CO2 sensor drift to better than ± 10 ppm per year. Change with the <ROLL> key and save using <SAVE>. ON is recommended for applications where the CO2 level will be close to normal (400 ppm) at least once per day. If a building is occupied 24 hours and the CO2 level is fairly constant then this should be set to OFF.

<MENU>

4. Temp C/F °F The temperature scale defaults to Fahrenheit (°F). It can be changed to Celsius (°C) using the <ROLL> key. Save changes by using the <SAVE> key.

<MENU>

5. T Range 32-95 °F Two temperature ranges are available, 0-35 °C (32-95 °F) or 0-50 °C (32-122 °F). This can be changed using <ROLL> and saved with <SAVE>. The available range will depend on the C or F menu selection.

<MENU>

6. Display Mode 4 Select parameters normally displayed on the LCD. 1 = CO2 only, 2 = CO2 + RH , 3 = CO2 + T and 4 = CO2 + RH + T. The factory default is 4.

<MENU>

7. T Offset 0 °F This item allows calibration of the temperature sensor. Use <ROLL> to add an offset to the temperature signal and display, then press <SAVE>. -1 subtracts 1 degree Fahrenheit from the temperature and +1 adds 1 degree F to the temperature. The range is -9 to +9 °F.

<MENU>

8. H Offset 0 %RH This item allows calibration of the RH sensor. Use <ROLL> to add an offset to the RH signal and display, then press <SAVE>. -1 subtracts 1 %RH and +1 adds 1 %RH. The range is -10 to +10.

<MENU>

Items 9, 10 and 11 are only available if the Relay Option is installed, otherwise the menu skips directly to step 12.

9. Relay SP 1000 ppm The relay trip setpoint default is 1000 ppm. It can be changed from 500 to 5000 in 100 ppm increments for the 2000 ppm CO2 sensor or 500 to 15,000 for the 20,000 ppm sensor. Save changes by using the <SAVE> key.

<MENU>

10. Relay Hy 50 ppm The relay hysteresis default is 50 ppm. This can be changed from 25 to 200 in 25 ppm increments for the 2000 ppm sensor or 25 to 500 ppm for the 20,000 ppm sensor. Use <SAVE> to save any change.

<MENU>

11. Relay Test OFF Use the <ROLL> key to toggle the relay ON or OFF for testing purposes. Press either <SAVE> or <MENU> to turn the relay off and advance to the next item.

<MENU>

This item is omitted for 4-20 mA current output models

12. Out Type 0-5 Vdc The factory default output type is 0-5 Vdc. Use the <ROLL> key to change the value to 0-10 Vdc if necessary. Press the <SAVE> key to save.

<MENU>

13. Output Test OFF Use the <ROLL> key to toggle all outputs OFF (normal operation), MIN (minimum output) or MAX (maximum output) for testing purposes. Press either <SAVE> or <MENU> to set it back to OFF and advance to the next item.

<MENU>

This item is omitted if the 2000 ppm CO2 sensor is installed

14. Calibrat 0 PPM This item is used for 0 ppm gas calibration and is explained in the *Calibration* section.

<MENU>

15. Calibrat 1000 PPM This item is used for 1000 ppm gas calibration and is explained in the *Calibration* section.

<MENU>

This item is omitted if the 2000 ppm CO2 sensor is installed

16. Calibrat 20000 PPM This item is used for 20,000 ppm gas calibration and is explained in the *Calibration* section.

<MENU>

17. BackLite Enable Use the <ROLL> key to enable or disable the LCD backlight. When enabled the backlight is always on, when disabled it never lights. Press the <SAVE> key to save the setting. The factory default is Enable.

<MENU>

18. Restore Defaults Press the <SAVE> key to restore all factory defaults and calibration to original factory settings.

<MENU>

19. Menu Exit Press <SAVE> to exit the menu and return to normal operation or <MENU> to repeat the menu.

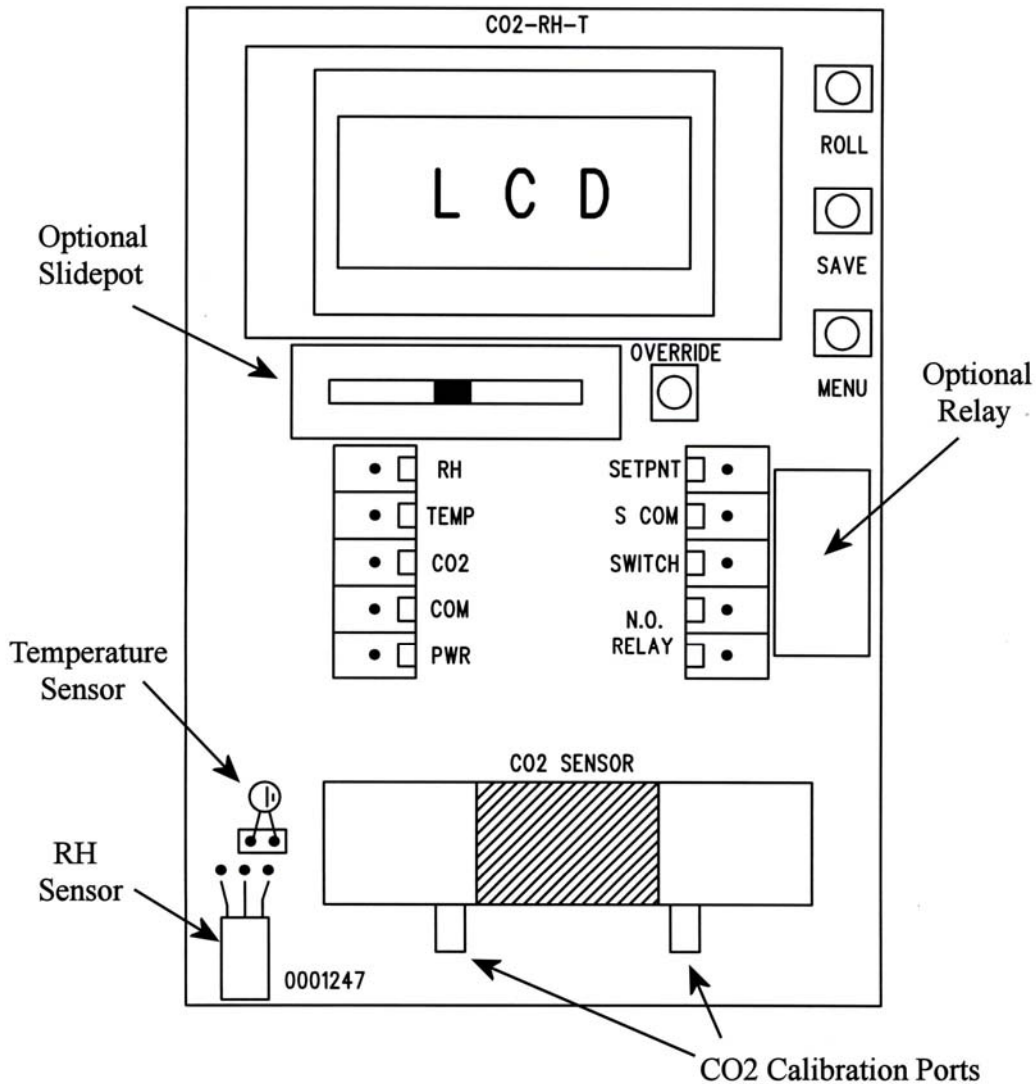

General Specifications

Power Supply	20 – 28 Vac/dc (non-isolated half-wave rectified)
Consumption	145 mA max @ 24 Vdc, 260 mA max @ 24 Vac (mA models) 85 mA max @ 24 Vdc, 150 mA max @ 24 Vac (voltage models)
Output Signals	4-20 mA active (sourcing) or 0-5 Vdc / 0-10 Vdc
Output Drive Capability	550 ohms maximum for current output, 5 Kohm min for voltage output
Output Resolution	10 bit PWM
Input Voltage Effect	Negligible over specified operating range
Protection Circuitry	Reverse voltage protected, overvoltage protected
Operating Conditions	0-50 °C (32-122 °F), 0-95 %RH non-condensing
LCD Resolution	1 ppm CO2
LCD Size	1.4" w x 0.6" h (35 x 15 mm) alpha-numeric 2 line x 8 characters
LCD Backlight	Enable or disable via keypad
Wiring Connections	Screw terminal block (14 to 22 AWG)
Enclosure	Wall mount enclosure, 3.3" w x 4.7" h x 1.15" d (84 x 119 x 29 mm)

CO2 Signal

Measurement Type	Non-Dispersive Infrared (NDIR), diffusion sampling
Measurement Range	0-2000 ppm, (CDD5A/B), 0-20,000 ppm (CDD5C/D), programmable span
Standard Accuracy	± 30 ppm + 3% of reading (CDD5A/B with Auto Cal) ± 75 ppm or 10% of reading (whichever is greater) (CDD5C/D with dual channel sensor)
Temperature Dependence	0.2 %FS per °C
Stability	< 2 %FS over life of sensor (15 year typical) (CDD5A/B) < 5 %FS or < 10% of reading annual (CDD5C/D)
Pressure Dependence	0.135 % of reading per mm Hg
Altitude Correction	Programmable from 0-5000 ft via keypad
Response Time	< 2 minutes for 90 % step change typical
Warm-up Time	< 2 minutes

Temperature Signal

Sensing Element	10K thermistor, ± 0.4 °F (± 0.2 °C)
Range	32-95 °F (0-35 °C) or 32-122 °F (0-50 °C) selectable via keypad

RH Signal

Sensor	Thermoset polymer based capacitive
Accuracy	± 2 %RH
Range	0-100 %RH, non-condensing
Hysteresis	± 3 %RH
Response Time	15 seconds typical
Stability	± 1.2 %RH typical @ 50 %RH in 5 years

Optional Relay Output

Contact Ratings	Form A contact (N.O.) 2 Amps @ 140 Vac 2 Amps @ 30 Vdc
Relay Trip Point	Programmable via keypad
Relay Hysteresis	Programmable via keypad

Optional Override Switch . . Front panel push-button available as two-wire dry-contact output

Optional Slide Pot Front panel pot available as two-wire resistive output, 0-10 KΩ standard